

OFHG-7124

OFFICIAL FIELD HOCKEY GOALS WITH BOTTOM BOARDS

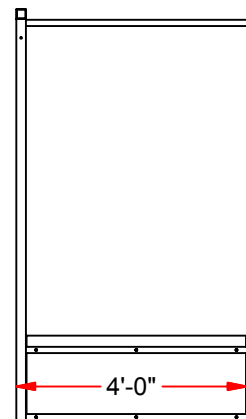
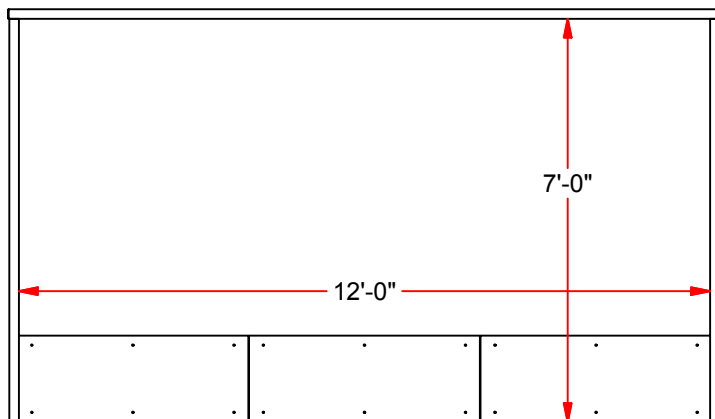
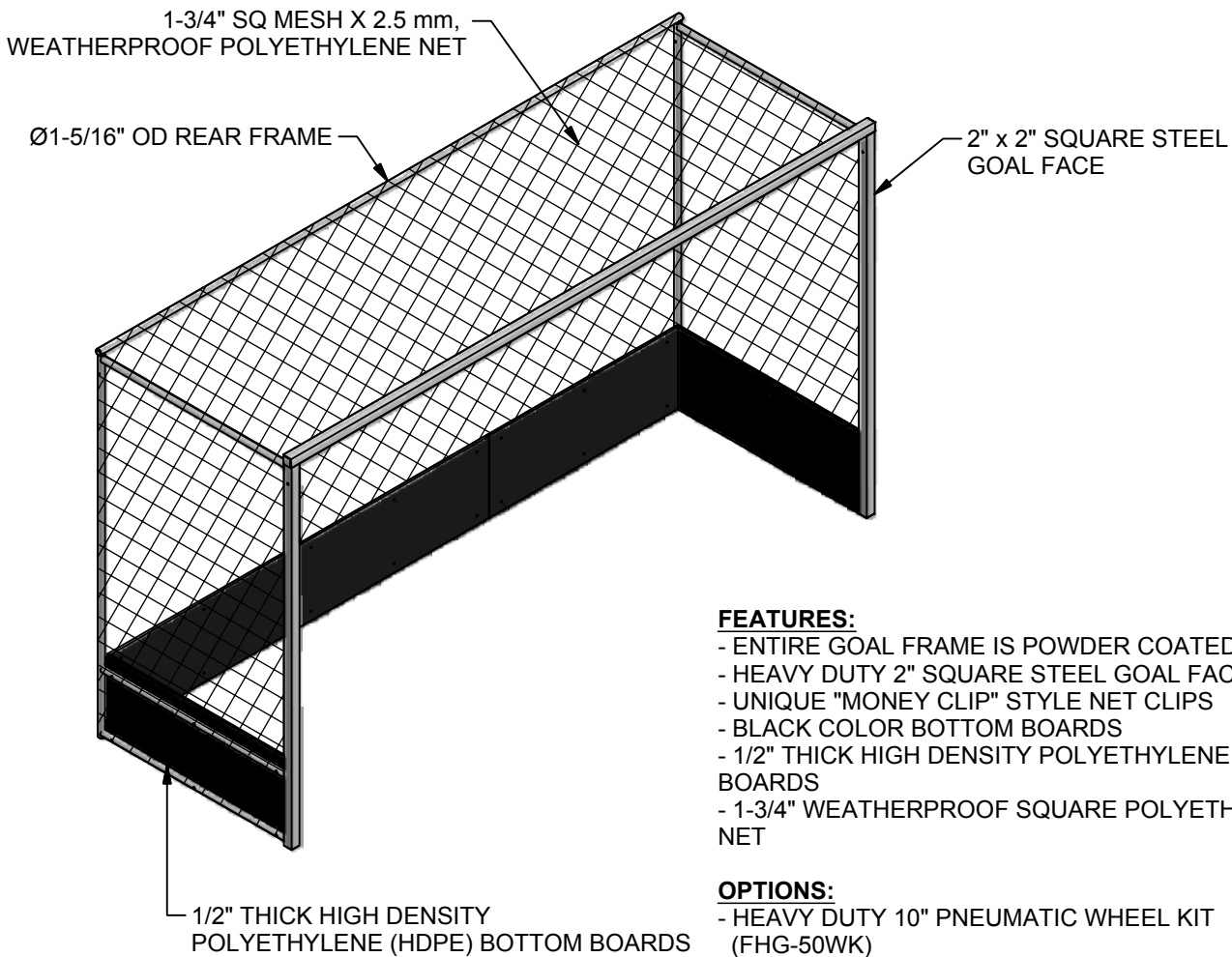

REV.	DESCRIPTION	DATE	BY
-	INITIAL	5/22	MT

COPYRIGHT 2006
JAYPRO SPORTS, LLC.
ALL RIGHTS RESERVED

OFHG-7124
OFFICIAL FIELD HOCKEY GOALS
WITH BOTTOM BOARDS

THIS PRINT IS THE PROPERTY OF JAYPRO SPORTS, LLC.
AND MAY NOT BE REPRODUCED WITHOUT WRITTEN PERMISSION

www.sportsedge.com

Jaypro
Sports Equipment
Since 1953

FAX: 704-528-0179 (Sales) PHONE: 800.334.6057 (TOLL FREE)

AS SUPPLIED BY SPORTSEGE - 259 MURDOCK RD - TROUTMAN, NC 28166

DRAWING NAME / PART NUMBER: OFHG-7124	
DRAWN BY: Moune T.	ISSUE DATE: 5/22/2009
CHK'D BY: WVB	REV. -
SHEET: 1 OF 1	

OFFICIAL FIELD HOCKEY GOAL OFHG-7124

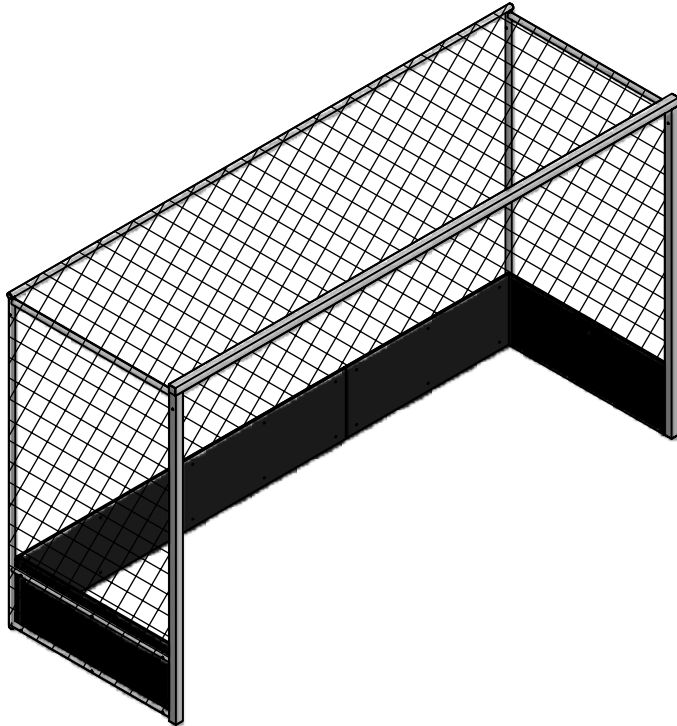



IMPORTANT NOTICE:

- 1) BEFORE EACH USE CHECK EQUIPMENT FOR PROPER CONNECTING HARDWARE AND STRUCTURAL INTEGRITY. REPLACE DAMAGED OR MISSING HARDWARE IMMEDIATELY.
- 2) USE OF THIS EQUIPMENT OTHER THAN INTENDED, MAY BE HAZARDOUS.
- 3) ALTERATION OR MODIFICATION OF THIS EQUIPMENT MAY BE HAZARDOUS AND RESULT IN INJURY. FOR REPAIR OR REPLACEMENT, CONTACT YOUR DEALER OR JAYPRO SPORTS.

TOOLS REQUIRED:

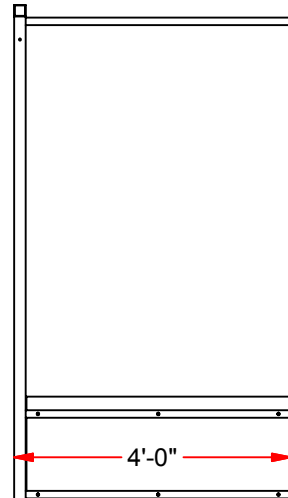
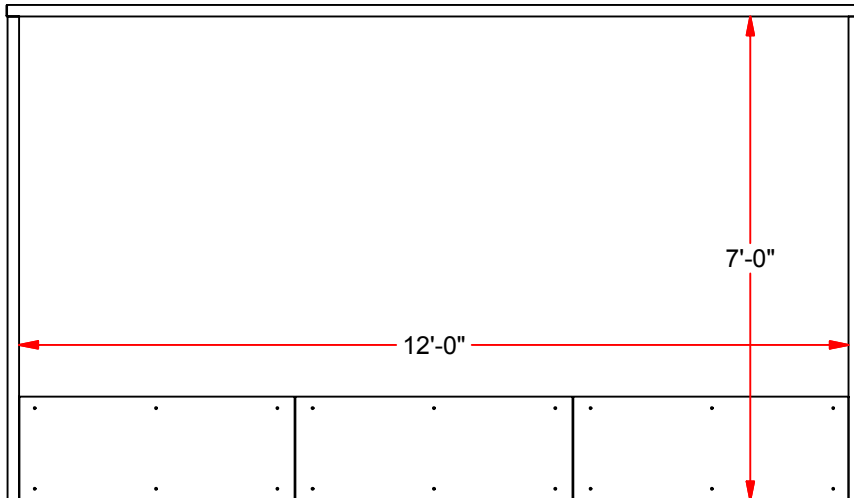
- (1) 5 mm Allen Wrench
- (1) 13 mm Closed End Wrench or Socket
- (1) Rubber mallet



 AS SUPPLIED BY SPORTSEGE 800-334-6057	MODEL NUMBER: OFHG-7124	CHECKED BY: WVB
	PRODUCT NAME: OFFICIAL FIELD HOCKEY GOAL ASSEMBLY INSTRUCTION PACKAGE	
EFFECTIVE DATE: 5/22/2009	DRAWN BY: Moune T.	

JAYPRO SPORTS
OFHG-7124, OFFICIAL FIELD HOCKEY GOAL

IMPORTANT NOTICE:

- 1) BEFORE EACH USE CHECK EQUIPMENT FOR PROPER CONNECTING HARDWARE AND STRUCTURAL INTEGRITY. REPLACE DAMAGED OR MISSING HARDWARE IMMEDIATELY.
- 2) USE OF THIS EQUIPMENT OTHER THAN INTENDED, MAY BE HAZARDOUS.
- 3) ALTERATION OR MODIFICATION OF THIS EQUIPMENT MAY BE HAZARDOUS AND RESULT IN INJURY. FOR REPAIR OR REPLACEMENT, CONTACT YOUR DEALER OR JAYPRO SPORTS.

ASSEMBLY INSTRUCTIONS

TOOLS REQUIRED:

- (1) 5mm Allen Wrench
- (1) 13mm Closed End Wrench or Socket
- (1) Rubber mallet

- 1) Unpack all parts and check against parts list to ensure that all have been included.
- 2) Inspect all parts for damage. Report any damages to the trucking company.
- 3) Lay side frames (items 3, 4) on flat dry surface approximately 12 ft apart.
- 4) Insert both Rear Lower Crossbar (item 5) as shown in Detail A. Do not install hardware at this point.
- 5) Do the same for the other side.
- 6) Insert Top Rear Crossbar (item 2) into open end of both side frames. Install hardware as shown in Detail B.
- 7) Do the same for the other side.
- 8) Insert Top Front Crossbar (item 1) into open end. Install hardware as show in Detail C.
- 9) Do the same for the other side.
- 10) Tip goal into upright position. Install Rear Foot Boards (item 6) onto Rear Lower Crossbar (item 5) using hardware shown in Detail D. Lightly tap head of carriage bolt using rubber mallet to insert shank into board. Note: Do not over tighten nylock lock nut, as boards should be allowed to expand and contract without bowing.
- 11) Install Side Foot Boards (item 7) in same manner as Rear Boards.
- 12) Install net clips along inside surface of front frame (Refer to SNT-180 Instruction)
- 13) Lay out net and identify corner. Drape net over frame and insert lead front and top edges into net clip.

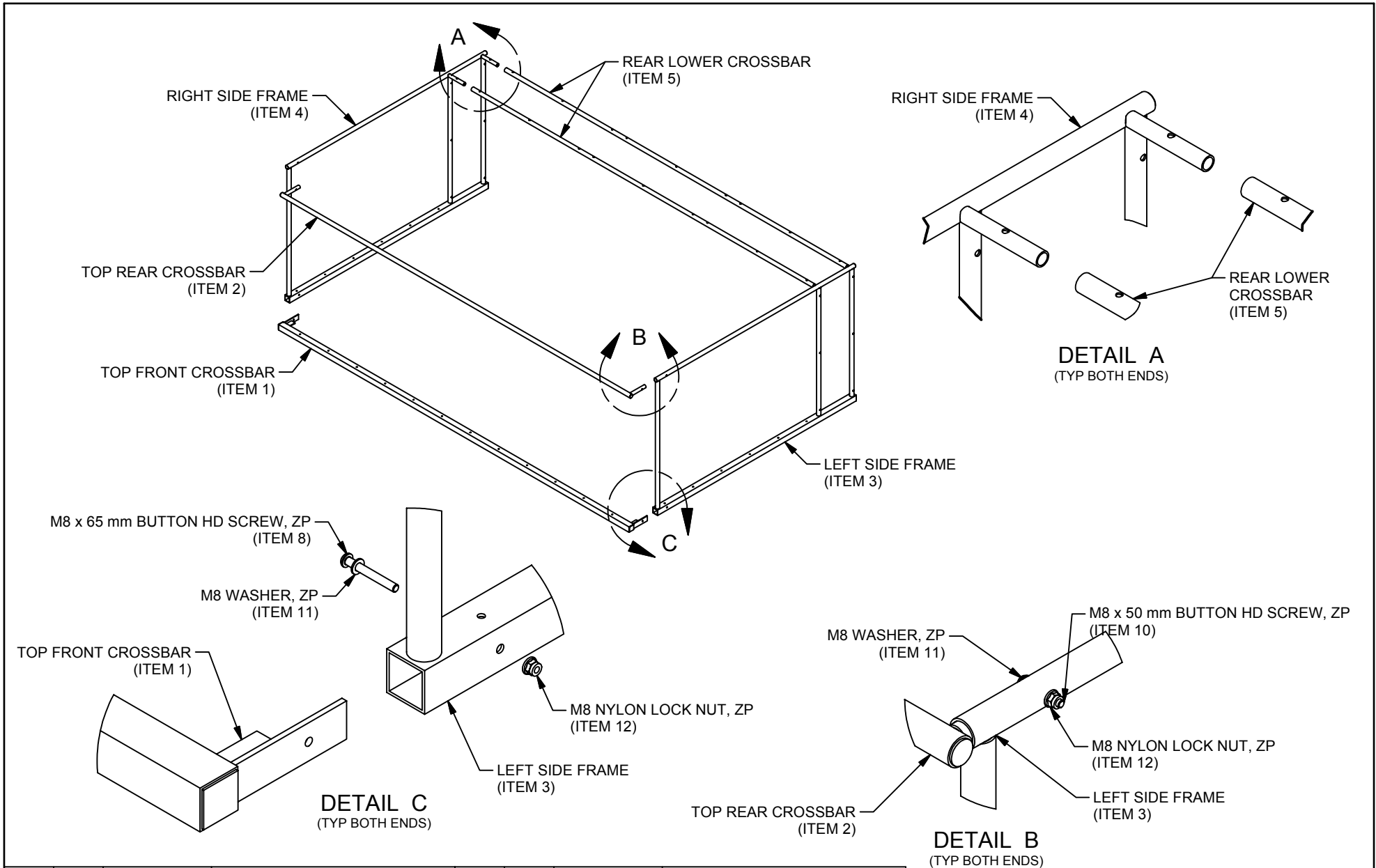

8	2	BOLT-A	M8 x 65 mm BUTTON HD SCREW, ZP	1	1	FHG-60-J1	TOP FRONT CROSSBAR
9	30	BOLT-B	M8 x 60 mm CARRIAGE BOLT, ZP	2	1	FHG-60-2	TOP REAR CROSSBAR
10	2	BOLT-C	M8 x 50 mm BUTTON HD SCREW, ZP	3	1	FHG-60-3	LEFT SIDE FRAME
11	4	WASHER-A	M8 WASHER, ZP	4	1	FHG-60-4	RIGHT SIDE FRAME
12	34	NUT-A	M8 NYLON LOCK NUT, ZP	5	2	FHG-60-5	REAR LOWER CROSSBAR
13	1	SNT-180	NET CLIP KIT	6	3	FHG-16-1	REAR FOOT BOARD x 48" LONG
14	1	FHND-8	7' x 12' x 4' WEATHERPROOF NET	7	2	FHG-16-2	SIDE FOOT BOARD x 45 1/2" LONG
ITEM	QTY	PART NUMBER	DESCRIPTION	ITEM	QTY	PART NUMBER	DESCRIPTION



AS SUPPLIED BY
SPORTSEGE
800-334-6057

MODEL NUMBER:
OFHG-7124

PRODUCT NAME:
**OFFICIAL FIELD HOCKEY GOAL
ASSEMBLY INSTRUCTION PACKAGE**

EFFECTIVE DATE:
5/22/2009

CHECKED BY:
WVB

DRAWN BY:
Moune T.

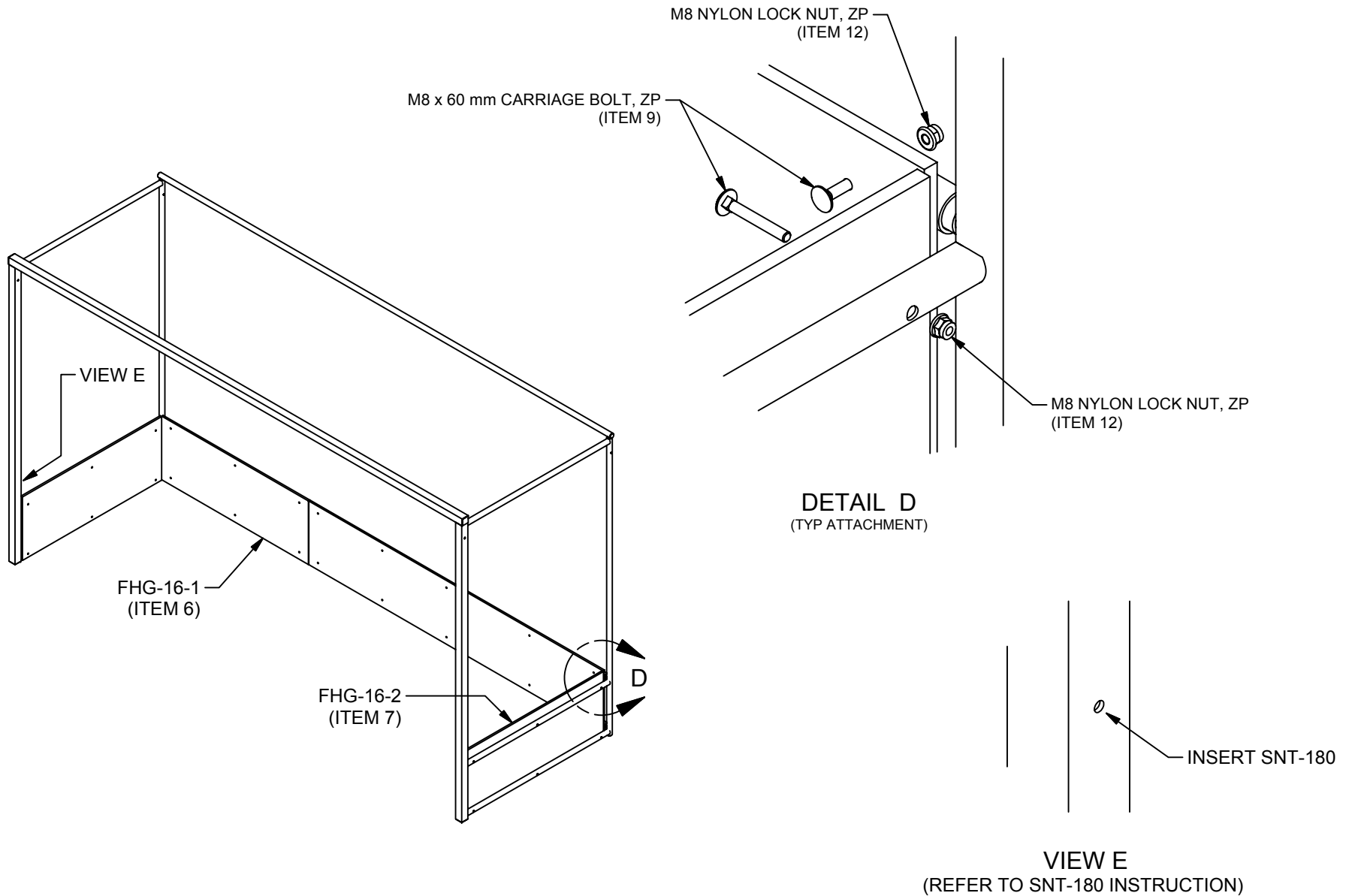

8	2	BOLT-A	M8 x 65 mm BUTTON HD SCREW, ZP	1	1	FHG-60-J1	TOP FRONT CROSSBAR
9	30	BOLT-B	M8 x 60 mm CARRIAGE BOLT, ZP	2	1	FHG-60-2	TOP REAR CROSSBAR
10	2	BOLT-C	M8 x 50 mm BUTTON HD SCREW, ZP	3	1	FHG-60-3	LEFT SIDE FRAME
11	4	WASHER-A	M8 WASHER, ZP	4	1	FHG-60-4	RIGHT SIDE FRAME
12	34	NUT-A	M8 NYLON LOCK NUT, ZP	5	2	FHG-60-5	REAR LOWER CROSSBAR
13	1	SNT-180	NET CLIP KIT	6	3	FHG-16-1	REAR FOOT BOARD x 48" LONG
14	1	FHND-8	7' x 12' x 4' WEATHERPROOF NET	7	2	FHG-16-2	SIDE FOOT BOARD x 45 1/2" LONG
ITEM	QTY	PART NUMBER	DESCRIPTION	ITEM	QTY	PART NUMBER	DESCRIPTION



MODEL NUMBER: OFHG-7124	CHECKED BY: WVB
PRODUCT NAME: OFFICIAL FIELD HOCKEY GOAL ASSEMBLY INSTRUCTION PACKAGE	
EFFECTIVE DATE: 5/22/2009	DRAWN BY: Moune T.