

TrenchFormer®

Trench Drain Forming System Design Manual

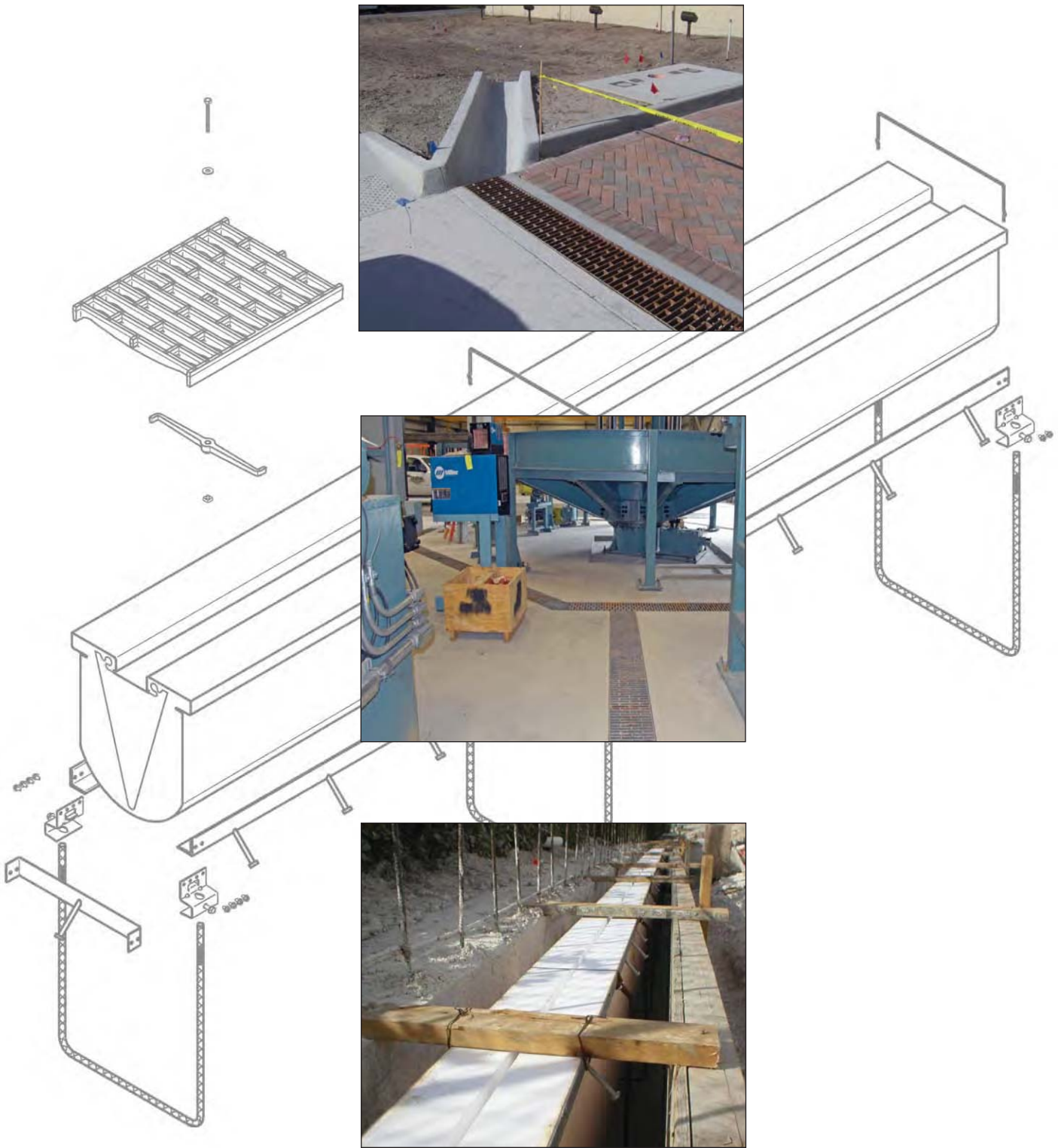



Trench Former

Trench Former is the pre-engineered concrete forming system which allows the designer or customer to select the trench width, depth, shape and slope as the hydraulic capacity or cross-sectional area requires, and not from a limited product selection. It also creates a sound base for trench coating if concrete's chemical resistance is insufficient.

Product Features:

Formers - Manufactured from expanded polystyrene (EPS), the light-weight and environmentally sound disposable formers create a high precision monolithic trench. Shape may be either square or radius bottom, whichever shape is best for the application. A full range of outlet options exist.

Grate Options - A wide range of grate and cover options exist for pedestrian to airport applications. Select the right strength, style, and corrosion resistance for the application.

For applications with substantial horizontal loads, pin locks are available and recommended. Toggle locks can be used when horizontal

loads are low. No grate locks are common in applications where the weight of the grates are adequate retention for the applications. ABT can assist you in making a suitable selection.

Frame Options - Stainless steel, painted steel, galvanized steel, and FRP styles are available. Select the best rail material for your application. Rail size is determined by trench width and the specified traffic loads. All rails are independently anchored into the surrounding concrete for maximum service life.

Ease of Installation - The system is installed by the suspension method using no-float legs. Installing the system does not require heavy equipment, expensive highly-skilled labor, keyways, or water stops saving 33% or more. Installed per instructions, the system will not float. Contact ABT for alternative methods.

Eliminates Sub-Slab Barrier Penetration -

Geo-membrane penetrations during trench drain installation and monolithic pours are eliminated using no-float legs and anchor slab.



U.S. Patents #5,348,421; #5,393,171; #5,281,051; #5,478,169; #5,573,350 and #5,702,204. Other patents pending. Trench Former is a registered trademark of ABT, Inc.

Example of Typical 12" System

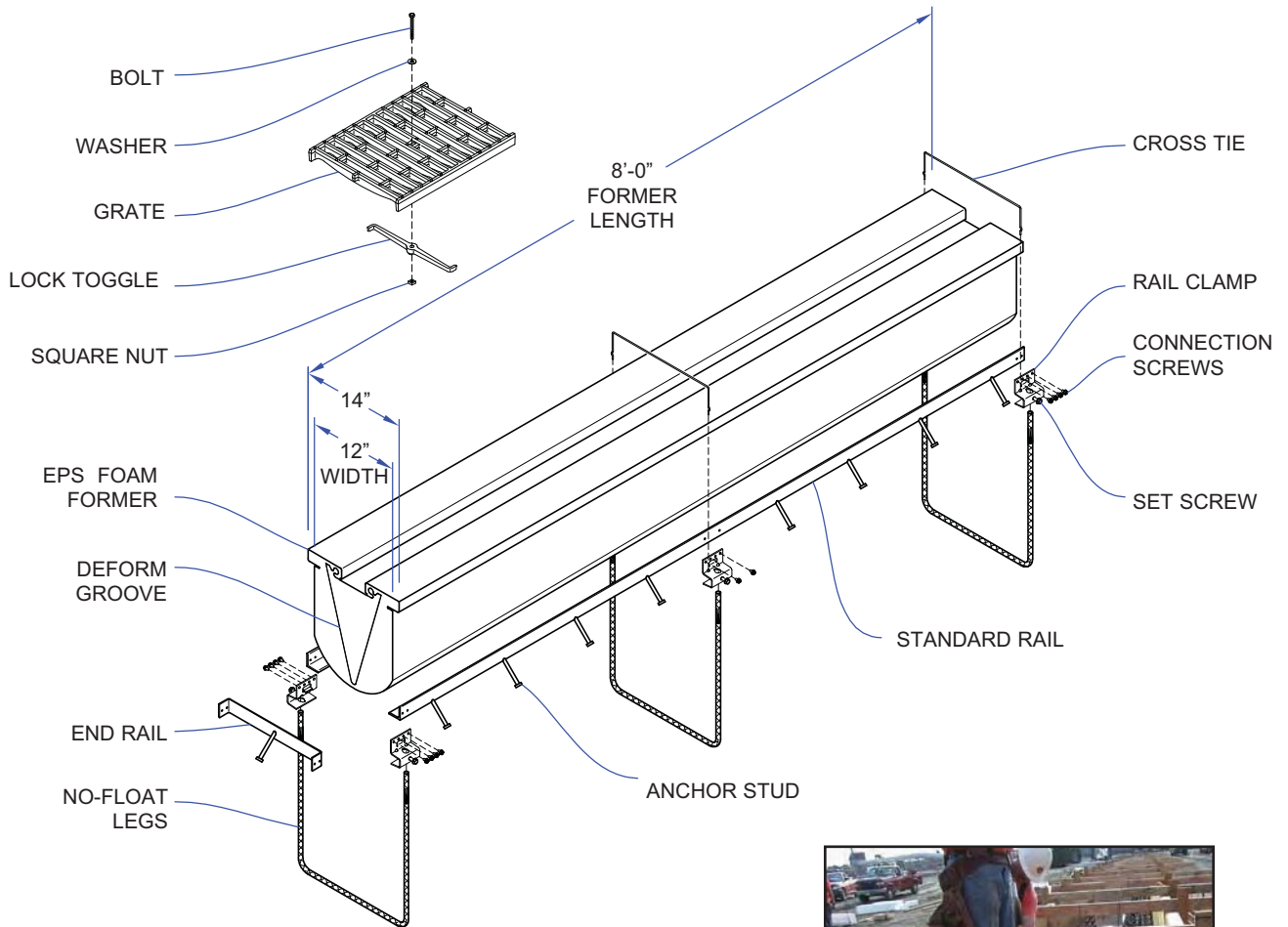

TrenchFormer is a trench forming system that utilizes standard metal components and customizable forming sections. Its components are made in the most commonly constructed sizes.

They have integral deforming grooves for easy removal and full length longitudinal grooves for coplanar rail spacing and alignment.

The steel angle rails include anchoring studs welded on predetermined centers to the outside corners. U-shaped no-float legs (#4 rebar) attach to rail clamps on each rail. Each rail end is designed to accept a rail clamp which connects adjacent rail segments.

Prefabricated L-rail and T-rail assemblies allow for field installation of 90° turns anywhere in the pre-

sloped layout.

Outlet piping is butted to an annular groove made in the EPS form prior to concreting. For trench junctions or for large outlet sizes, four catch basins are provided. A wide selection of retainable grates and solid covers are available for various loadings.





EPS Forms

Our EPS forms include unique deforming grooves which keep the foam segments together during the concrete pour. Each form can be pre-sloped or neutral with a radius, or square bottom. Non-sloping lengths are 4 ft. and 8 ft. Part identifiers are marked on the deep (downstream) end of each section.



Rails

Structural steel rails are manufactured in five lengths: 8, 6, 4, 3 and 2 ft. The ends of all the rails are punched to receive the rail clamps on which the no-float legs and cross ties are attached. Anchor studs are welded on predetermined centers. Standard rail components are a powder coated black epoxy paint and are also available in hot dip galvanized if required.

Finishes: Black Epoxy , Galvanized, Stainless Steel and FRP.

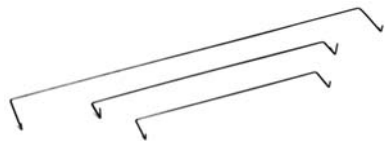

Cross-Ties

Cross-ties help hold rails tight to the foam former for consistent spacing of grates and aesthetically pleasing trenches.

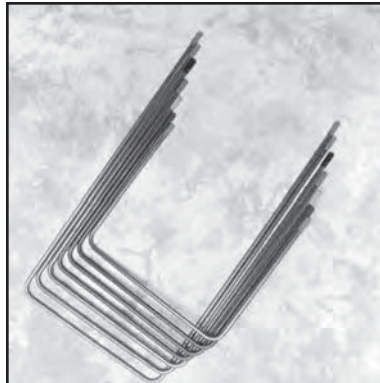

No-Float Legs

The eight no-float leg sizes are color coded to match their corresponding form sections for easy installation. This patented feature is at the heart of the Trench Former no-float guarantee. Legs are secured to rails by set screws for stability and strength.

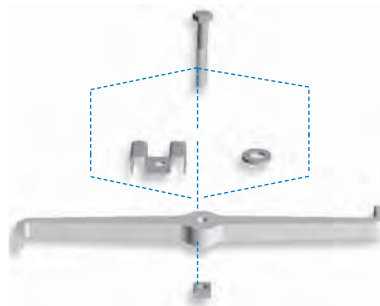

Grate Locking Devices

Lock toggles tie down grates by turning against the trench wall and securing to the underside of the steel rail.



End Frames

End frames close off the end of a trench run preventing concrete from entering the end of a trench. Rail Clamps will attach end frames to rails.



Outlet/Connects

Prior to concrete placement and where local plumbing codes allow, butt outlet pipe to former or connect former to catch basin.

As with any typical cast-in-place system, standard fittings may be used to connect to sanitary sewer or stormwater piping.

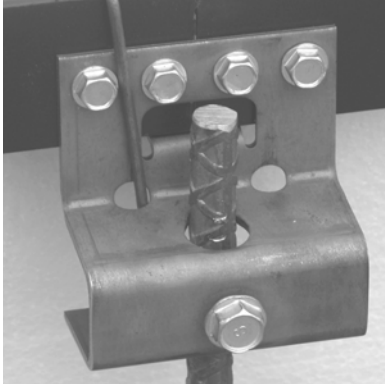

Rail Clamp

Rail clamps are used to connect all rail segments, end frames, and catch basin frames to prevent uneven joints. No-float legs and cross-ties are positioned into opposing rail clamps. The rail clamps provide longitudinal alignment, stiffness, and vertical adjustment.



Former Release

Former Release is a non-petroleum based product which is to be applied to all EPS forming surfaces. It provides good concrete release properties without attacking EPS foam and is available in one and five gallon cans. Form Release is best applied with a brush.



Auxillary Rail Assembly

Auxillary Rail Assemblies can be used to create non-loadbearing "T" and "L" assemblies in addition to the expansion joints, construction joints and radius assemblies.



T-Rail Assembly

When used in conjunction with a 4 ft. rail, a trench intersection is easily formed. Ideally, the intersecting form number should be at the same invert or a minimum of 6" less than the main trunk run. (For example, a 24" trunk run would be entered by a 18" intersection or less.) Minimum trench depth at assembly must be 7".



L-Rail Assembly

The L-rail assembly is used for right and left turns anywhere in trench layout. When the 8 ft. form is cut, and an adjacent set of 4 ft. rails is used, the form is fully utilized and the form/rail joints line up. Minimum trench depth at assembly must be 7".

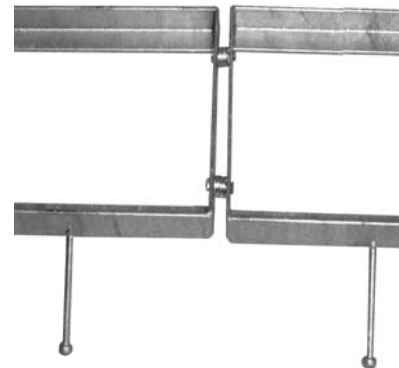

Auxillary Rail Assembly -Expansion Joint

Two Auxillary Rail assemblies can be joined to create an expansion joint



Auxillary Rail Assembly -Radius

Two auxillary rail assemblies can be used to create custom radius.

TrenchFormer

The most versatile trench drain system on the market

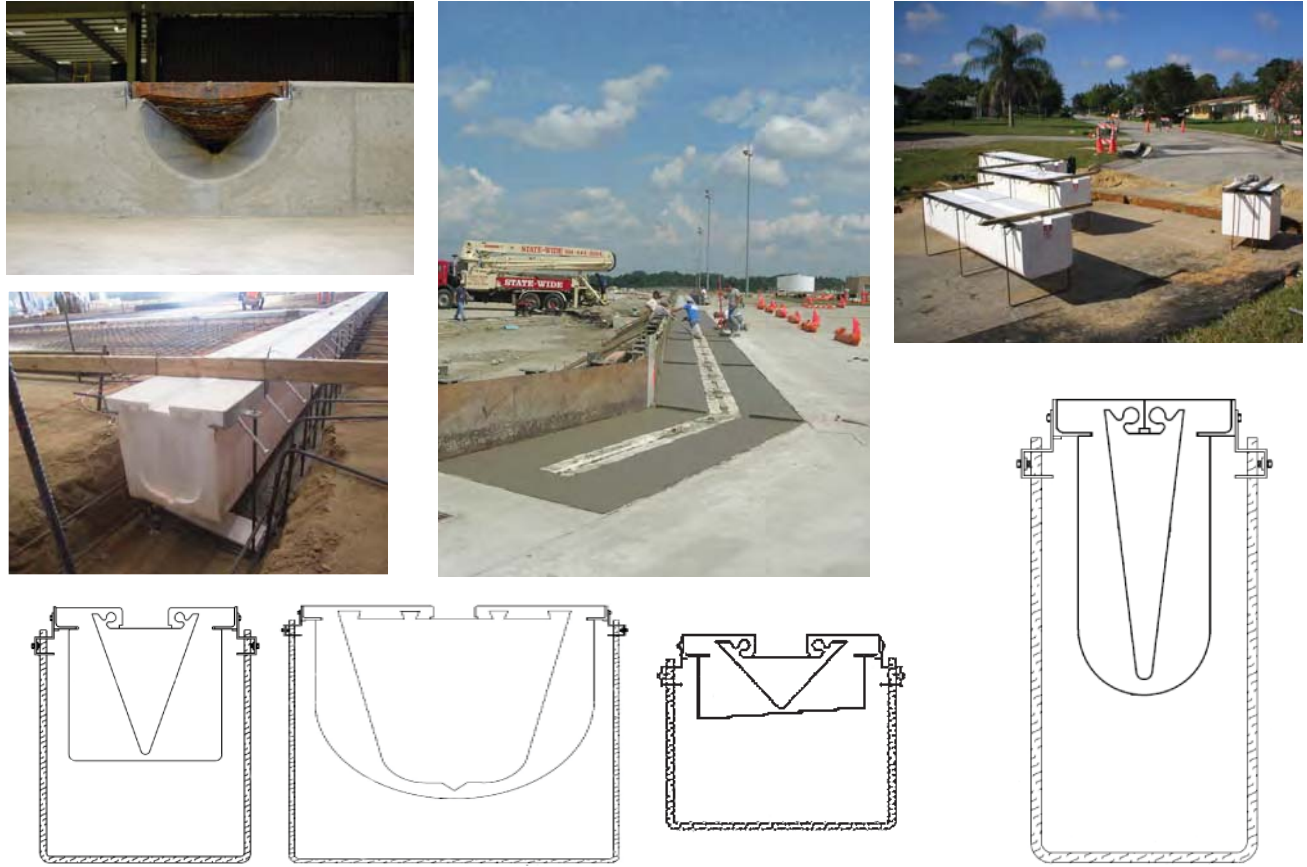

Flat Site Flow Capacity for 6"-24" trench width TFX Systems										
Slope	6" width (20" Max Depth)		8" width (36" max. depth)		12" width (36" max. depth)		18" width (42" max depth)		24"width (48" max depth)	
	Run Length Ft.	Flow Rate CFS @ Max. Depth	Run Length Ft.	Flow Rate CFS @ Max. Depth	Run Length Ft.	Flow Rate CFS @ Max. Depth	Run Length Ft.	Flow Rate CFS @ Max. Depth	Run Length Ft.	Flow Rate CFS @ Max. Depth
0.5%	250	2	512	7	500	12	550	29	558	52
1.0%	125	3	256	10	250	17	275	41	279	73
1.5%	83	4	170	11	166	21	183	50	186	90
2.0%	62	4	128	13	125	25	137	58	139	104
2.5%	50	5	102	15	100	28	110	65	111	116
3.0%	40	5	83	17	83	31	91	71	93	127

Flat Site Flow Capacity for 152mm-610mm trench width TFX Systems										
Slope	152 mm width (508 mm max. depth)		203 mm (914 mm max. depth)		304 mm (914 mm max. depth)		457 mm (1067 mm max. depth)		610 mm (1219 mm max. depth)	
	Run Length Meter	Flow Rate CMS @ Max. Depth	Run Length Meter	Flow Rate CMS @ Max. Depth	Run Length Meter	Flow Rate CMS @ Max. Depth	Run Length Meter	Flow Rate CMS @ Max. Depth	Run Length Meter	Flow Rate CMS @ Max. Depth
0.5%	76	0.06	156	0.20	152	0.35	137	0.82	170	1.47
1.0%	38	0.09	78	0.27	76	0.50	68	1.17	85	2.08
1.5%	25	0.11	52	0.33	50	0.61	45	1.43	57	2.55
2.0%	20	0.13	39	0.39	38	0.71	41	1.66	42	2.96
2.5%	15	0.14	31	0.43	30	0.80	33	1.85	33	3.30
3.0%	12	0.16	25	0.47	25	0.88	27	2.03	28	3.61

*** Other sizes and materials available. Please contact for availability ***



#208 Banded Bar Grating



#502 High Intake Slotted

Banded Bar Grating - 208 Series

Part No.	Trench Width	Load Class	Locking Mech.	Grate Length	Angle Size	Weight (lbs)	Open Area (ft ² per lin ft)
12.208C.FG	12"	C	T	24"	1 3/4"	19	0.9

Other Sizes Available

High Intake Slotted - 502 Series

Part No.	Trench Width	Load Class	Locking Mech.	Grate Length	Angle Size	Weight (lbs)	Open Area (ft ² per lin ft)
08.502F.GB	8"	F	T	19.64"	2"	18	0.47
12.502D.FB	12"	D	T	18"	1 3/4"	26.1	0.76
12.502E.GB	12"	E	T	19.64"	2"	35	0.81

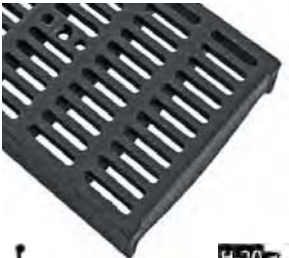

#504 8" Slotted ADA

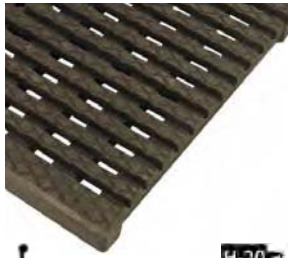

#504 12" Slotted ADA

Slotted ADA - 504 Series

Part No.	Trench Width	Load Class	Locking Mech.	Grate Length	Angle Size	Weight (lbs)	Open Area (ft ² per lin ft)
08.504F.FE	8"	F	T	16"	1 3/4"	21	0.27
12.504G.FB	12"	G	T	18"	1 3/4"	51	0.25

Slotted Heel Proof ADA - 506 Series

Part No.	Trench Width	Load Class	Locking Mech.	Grate Length	Angle Size	Weight (lbs)	Open Area (ft ² per lin ft)
08.506F.GB	8"	F	T	19.64"	2"	24	0.3



#506 Herringbone



#603 Standard Slotted

Standard Slotted - 603 Series

Part No.	Trench Width	Load Class	Locking Mech.	Grate Length	Angle Size	Weight (lbs)	Open Area (ft ² per lin ft)
06.603D.FB	6"	D	N	24"	1 3/4"	37	0.2
10.603D.FB	10"	D	N	24"	1 3/4"	53	0.4
18.603D.FB	18"	D	N	24"	1 3/4"	103	0.7
24.603D.FB	24'	D	N	24'	1 3/4'	143	0.9

Slotted Heel Proof - ADA - 606 Series

Part No.	Trench Width	Load Class	Locking Mech.	Grate Length	Angle Size	Weight (lbs)	Open Area (ft ² per lin ft)
06.606D.FB	6"	D	N	24"	1 3/4"	47	0.1
10.606D.FB	10"	D	N	24"	1 3/4"	69	0.1
12.606D.FB	12"	D	N	24"	1 3/4"	89	0.2
18.606D.FB	18"	D	N	24"	1 3/4"	106	0.5



#606 Slotted Heel Proof -ADA

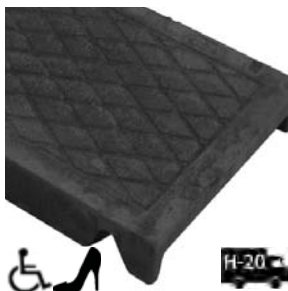

Solid Cover - Series

Solid Cover - Series

Part No.	Trench Width	Load Class	Locking Mech.	Grate Length	Angle Size	Weight (lbs)	Open Area (ft ² per lin ft)
08.601D.FB	8"	D	N	24"	1 3/4"	50	-
10.601D.FB	10"	D	N	24"	1 3/4"	80	-
12.501G.FB	12"	G	T	17.88"	1 3/4"	55	-
18.601D.FB	18"	D	N	24"	1 3/4"	129	-
24.601D.FB	24'	D	N	24'	2'	181	-

= Vehicular Traffic

= ADA Compliant

= Heel Proof

Load Classifications							
	A	B	C	D	E	F	G
Application Proof Load	75 psi	150 psi	310 psi	494 psi	620 psi	1235 psi	2469 psi
Typical Standard	Foot Traffic	Light Tire	A-A60005 Federal Spec	AASHTO M306 H-20	AASHTO M306 HS-25	Airport 100,000lbs	Airport/ Port 200,000lbs

Locking Mechanism

N = Non-Locking

T = Toggle

TrenchFormer Catch Basins are available in both the 1600 and 1900 series. The catch basins can be used at any point throughout a trench run as well as a termination point or a stand alone area drain. Both series utilize deforming grooves and a no-float leg system. The components are color coded for easy installation.

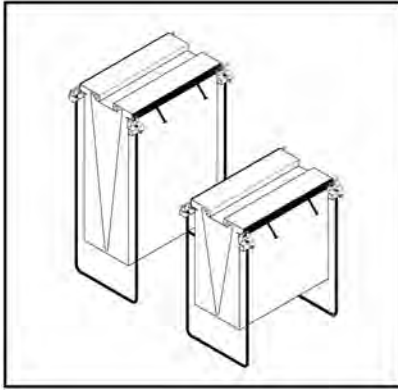

1900 Series Catch Basin

The 1900 series catch basins are 12 in. wide x 24 in. long flat bottom units, manufactured in 24 in. and 36 in. depths. They utilize 24 in. long rail, standard TrenchFormer grates, locking devices, and end rails.

#1900 (24 in. deep)
#1901 (36 in. deep)

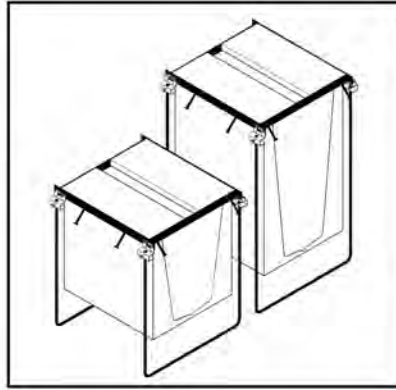

1600 Series Catch Basin

The 1600 series catch basins are 21 in. wide x 24 in. long and are available in both 24 in. and 36 in. depths. This series uses two 24 in. long frame rails two end frames and C.I. grate.

#1610 (21 X 24 X 24 in.)
#1611 (21 x 24 x 36 in.)

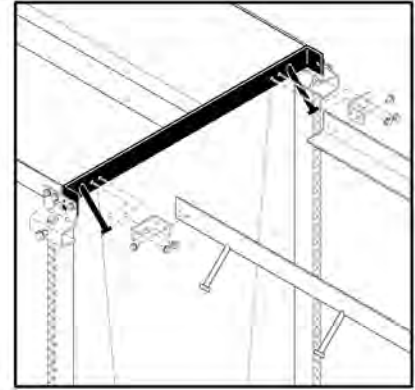

Special End Rail

If a 1600 series catch basin is used at the end of a trench run, brackets connect to rails and end frames. This aligns and retains the end of the trench rails for a secure and precise fit.

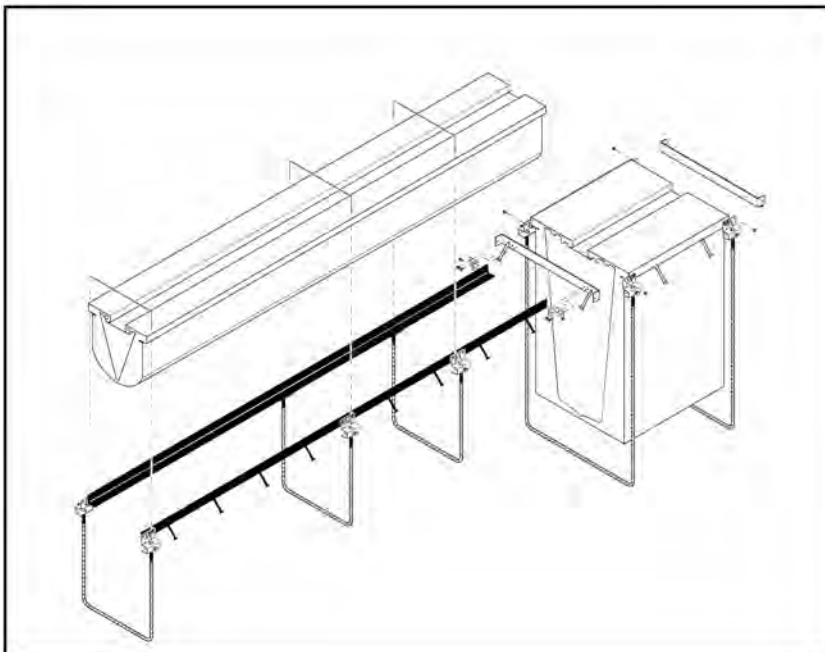

TrenchFormer Assembly Schematic

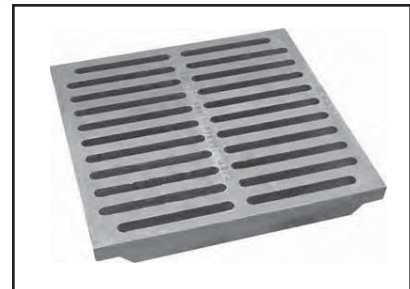

1600 Series Grate

The catch basin grate is 23 x 24 x 1-1/2 in. cast iron and meets AASHTO H-20 Load Rating.



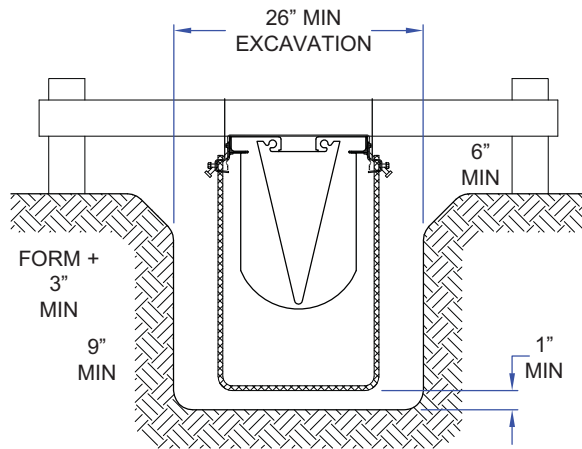

Figure 1

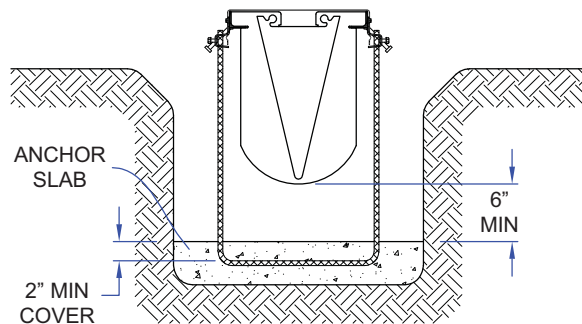

Figure 2

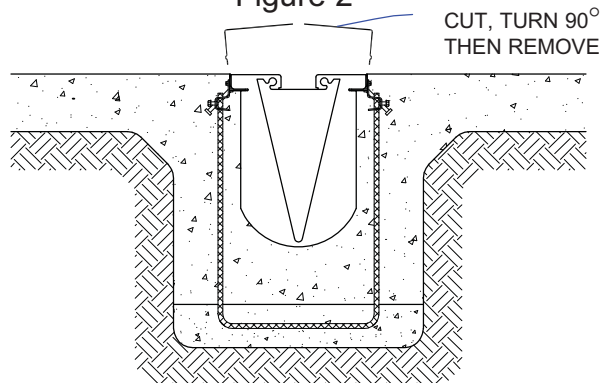

Figure 3

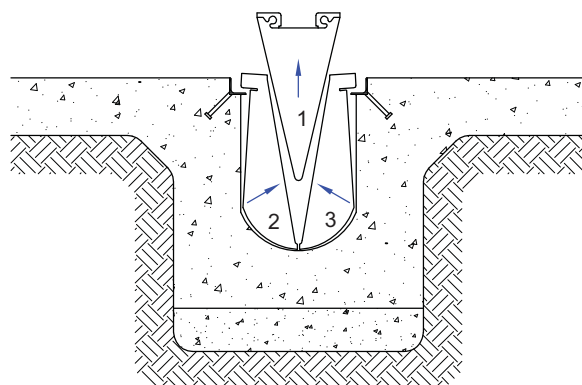

Figure 4

DISCLAIMER

The customer and the customer's architects, engineers, consultants and other professionals are completely responsible for the selection, installation, and maintenance of any product purchased from ABT, and EXCEPT AS EXPRESSLY PROVIDED IN ABT'S STANDARD WARRANTIES, ABT MAKES NO WARRANTY, EXPRESS OR IMPLIED, AS TO THE SUITABILITY, DESIGN, MERCHANTABILITY, OR FITNESS OF THE PRODUCT FOR CUSTOMER'S APPLICATION. Copies of ABT's standard warranties are available upon request. PolyDrain[®], Trench Former[®], and TF-14[®] are registered trademarks of ABT, Inc.

Excavation

Excavation must provide for 6 inches (minimum) on both sides of the former and 9 inches (minimum) on the bottom. Structural slabs may require additional excavation. Consult your structural engineer. Bottom allowance includes 3 inches of clearance for the no-float U-legs and anchoring slab. Excavate to match former numbers provided. Each 8 foot section has 2 equal length U-legs, so the excavation should be a series of step-down sections.

Assembly

Mix form release and apply to the bottom and sides of all the formers. Allow form release to dry completely. DO NOT USE PETROLEUM BASED FORM RELEASE - it will severely attack the EPS foam. Lay out the former and rail sections along the excavation in the proper sequence. Former and U-legs are color-coded for easy assembly. Match color on U-legs to the colored part number marked on the end of former. Assemble all rails, legs, and formers. Connect rail clamps to the rails, one on an end and one in the middle. With the former upside-down, push each rail into the groove of the former. Attach the U-legs to the rails by inserting each U-leg into the holes of opposing rail clamps. Use set screws to hold the U-leg in position. Turn the former upright and install a Cross Tie tightly across rails to ensure a snug fit and precise grate seat dimension. Join sections together into 16 foot lengths using the rail brackets.

Component Placement

Begin installation at the outlet / deep end of the trench. Attach a length of supporting lumber near each joint (at anchor studs). Hold the top of rail to finished grade and attach lumber to grade stakes. See Figure 1. Butt the next section against the one in position, attach to rail clamps, and then set to elevation. To assist in alignment once sections are in place, 2 x 4's can be fitted inside the alignment groove and nailed to the supporting lumber.

Concrete Placement

Place a concrete anchoring slab wall-to-wall and end-to-end in the bottom of the excavation. Cover the U-legs with 2 inches (minimum) of concrete. Allow this slab to set hard, and then remove the supporting lumber. See Figure 2. Monopour trench bottom and walls, vibrating at the rails for good consolidation. While finishing concrete, remove Cross Ties by cutting in half, turning 90° and lifting them out. See Figure 3.

Deforming

After 24 hours, you can deform the trench. Drive a pry bar between former and trench floor, exerting upward force. The center V-shaped section will break free and can be easily removed. Pull remaining pieces from the wall and remove. See Figure 4.

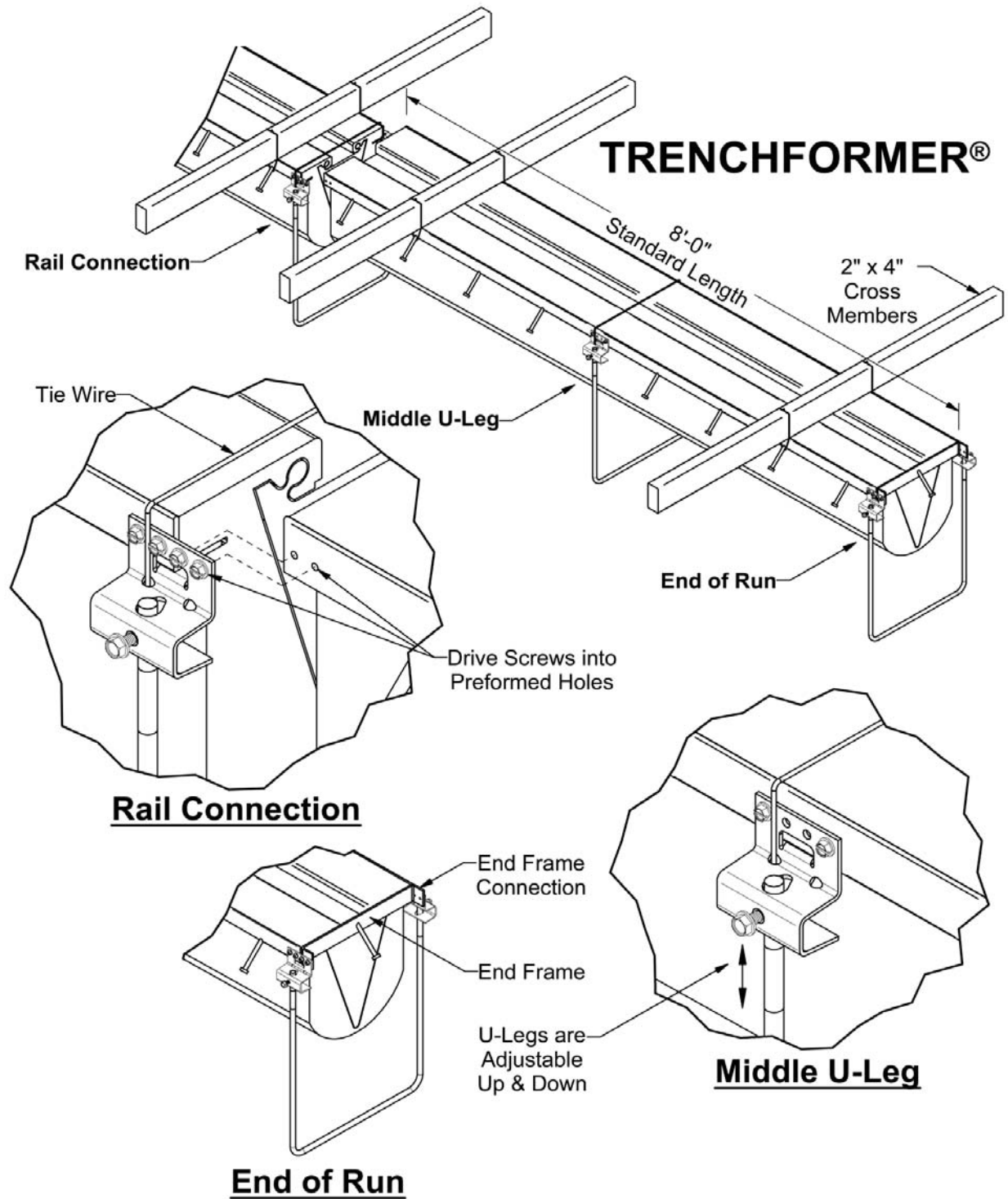

Disclaimer: The customer and the customer's architects, engineers, consultants and other professionals are completely responsible for the selection, installation, and maintenance of any product purchased from ABT, and except as expressly provided in ABT's standard warranties, ABT makes no warranty, express or implied, as to the suitability, design, merchantability, or fitness of the product for customer's applications. Copies of ABT's standard warranties are available upon request.

TrenchFormer has revolutionized trench drain installation and performance. Check out the differences between TrenchFormer and hand forming.

TrenchFormer

- Creates monolithic trench walls and floor.
- Rail accuracy assured by precision cut foam shapes.
- Hundreds of feet installed per day with a 2 laborer crew.
- Simple wood supports used for holding sections to grade.
- Standard radius bottom improves flow.
- Forms can be left in for jobsite safety.
- Fast, low cost deforming.
- All necessary trench components available from one source in off-the-shelf design.

Hand Forming

- Requires installation of keyway and waterstop at cold joint.
- Complex carpentry skills required to create coplanar rails.
- 2 skilled carpenters average 50 feet per day.
- Requires sturdy and complex wooden form work.
- Square bottom creates turbulence and deposits.
- Open pits are hazardous and collect jobsite debris.
- Forms must be re-used to be economical
- Three separate sources for materials create risk of dimensional inaccuracies.

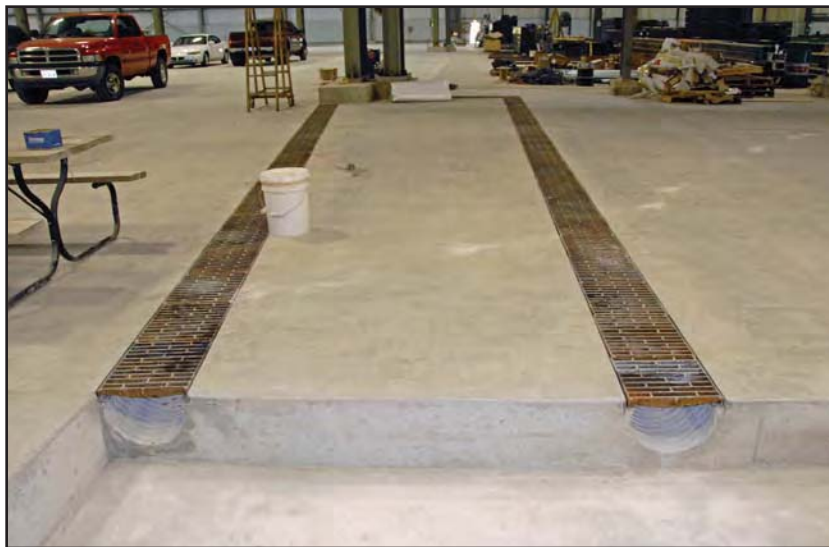

Please visit our website for the latest:

- Details
- Specifications
- Catalog Updates

ABT, INC.

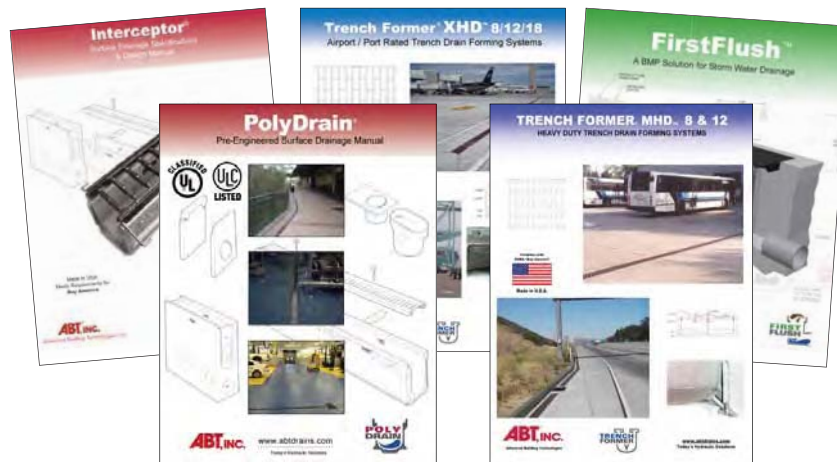

Other quality drainage products by ABT, Inc.



The information contained within is believed to be accurate but not guaranteed to be so. The customer should evaluate the suitability and safety of these products for any application. ABT assumes no liability for the end results since the conditions of installation and use are beyond the control of ABT. Concrete specifications, placement, reinforcement and structural considerations are the responsibility of the customer. ABT reserves the right to change the price, availability, specifications, and content of any of its products, literature or other information in all media at any time without notification.