

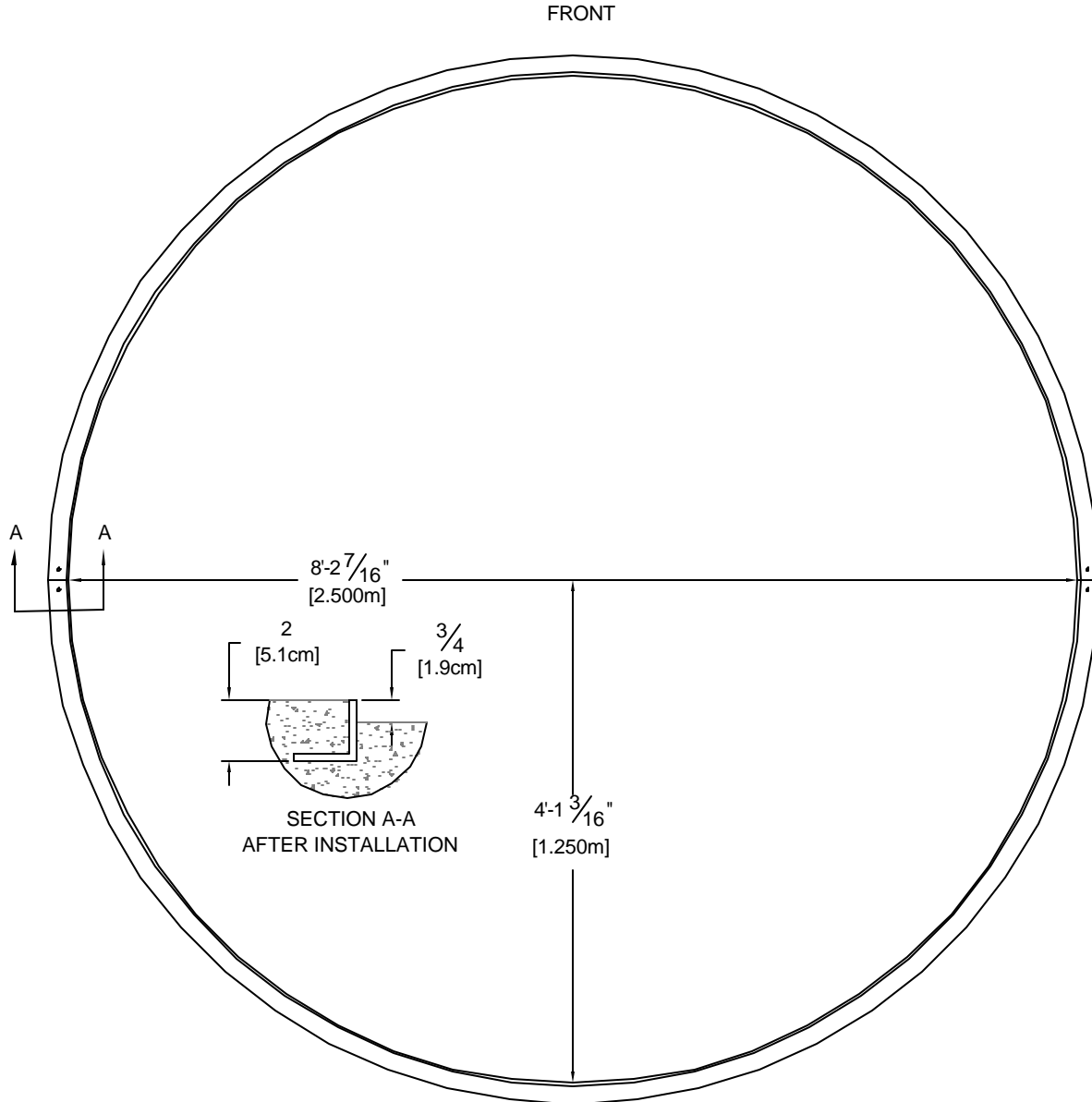

**SE375 - ALUMINUM DISCUS CIRCLE
(FOR 3/4" [19mm] DEPRESSED PAD)**

SPECIFICATIONS

The SE375 Aluminum Discus Circle is designed to be incorporated into concrete to form a 3/4" [19mm] deep depressed pad. The circle consists of two half sections fabricated from 2" x 2" x 1/4" [50.8mm x 50.8mm x 6.35mm], 6063-T5 aluminum sq corner angle. This circle meets NFSHSA, NCAA, and IAAF specifications.



Proprietary rights of ABT, Inc. are included in the information disclosed herein. The recipient, by accepting this document, agrees that neither this document nor the information disclosed herein nor any part thereof shall be copied, reproduced or transferred to others for manufacturing or for any other purpose except as specifically authorized in writing by ABT, Inc..

 A Division of ABT, Inc. P.O. Box 837 * 259 Murdock Road Troutman, NC 28166 800-334-6057	TITLE: SE375 Aluminum Discus Circle		
	DRAWN BY: C.C.C.	CHECKED BY:	DRAWING NUMBER: SE375-1
SCALE: NONE	DATE: 4/27/05	A —	
<small>DISCLAIMER : The customer and the customer's architects, engineers, consultants and other professionals are completely responsible for the selection, installation, and maintenance of any product purchased from ABT, and EXCEPT AS EXPRESSLY PROVIDED IN ABT'S STANDARD WARRANTIES, ABT MAKES NO WARRANTY, EXPRESS OR IMPLIED, AS TO THE SUITABILITY, DESIGN, MERCHANTABILITY, OR FITNESS OF THE PRODUCT FOR CUSTOMER'S APPLICATION. Copies of ABT's standard warranties are available upon request.</small>			

SE375 - ALUMINUM DISCUS CIRCLE DEPRESSED PAD INSTALLATION

INSTRUCTIONS FOR CIRCLE ASSEMBLY AND FORMS PLACEMENT

1. Lay circle sections out end to end on a flat surface. Check to ensure that the upper edges of both sections are flush with each other.
2. Locate the center of the circle and the pad with respect to the track and mark the required sector lines to properly orient the pad.
3. Position the forms as shown. The top of the forms should be leveled $\frac{3}{4}$ " [19mm] above the desired throwing surface height. Rules require the throwing surface to be on the same level as the landing area.

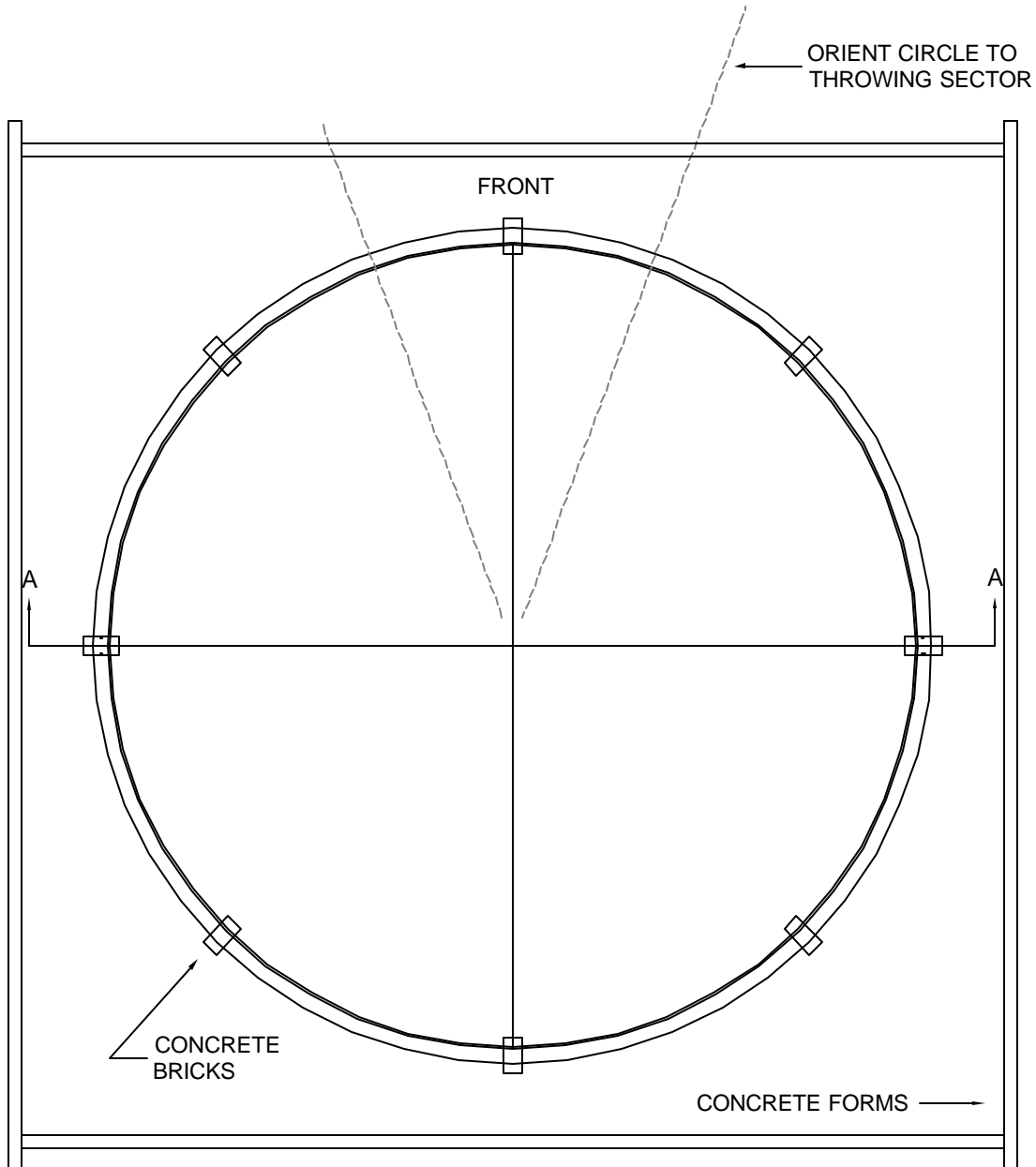

NOTICE: All installations should be done by experienced contractors and in accord with all applicable codes, laws and regulations. Suggested installation instructions herein are illustrative only and should be adapted to suit local requirements. SportsEdge is not responsible for the manner in which these products are installed.

Proprietary rights of ABT, Inc. are included in the information disclosed herein. The recipient, by accepting this document, agrees that neither this document nor the information disclosed herein nor any part thereof shall be copied, reproduced or transferred to others for manufacturing or for any other purpose except as specifically authorized in writing by ABT, Inc..

SportsEdge A Division of ABT, Inc. P.O. Box 837 * 259 Murdock Road Troutman, NC 28166 800-334-6057	TITLE: SE375 - Installation		
	DRAWN BY: C.C.C.	CHECKED BY:	DRAWING NUMBER: SE375-2
SCALE: NONE	DATE: 4/27/05	A	
<small>DISCLAIMER : The customer and the customer's architects, engineers, consultants and other professionals are completely responsible for the selection, installation, and maintenance of any product purchased from ABT, and EXCEPT AS EXPRESSLY PROVIDED IN ABT'S STANDARD WARRANTIES, ABT MAKES NO WARRANTY, EXPRESS OR IMPLIED, AS TO THE SUITABILITY, DESIGN, MERCHANTABILITY, OR FITNESS OF THE PRODUCT FOR CUSTOMER'S APPLICATION. Copies of ABT's standard warranties are available upon request.</small>			

SE375 - ALUMINUM DISCUS CIRCLE DEPRESSED PAD INSTALLATION

INSTRUCTIONS FOR SETTING CIRCLE AND POURING PAD

1. Position the circle in the center of the forms as shown in section A-A #1. The top edge of the circle must be held even with the top of the forms. If artificial track surface is to be installed around the circle, the top edge of the circle must be even with this surface. The circle forms should be lowered to match the thickness of the surface to be installed.
2. If required, install a drain. Position the drain to the side of the circle according to local requirements. Drains must not interfere with the athlete's throw.
3. Pour and level concrete in the center of the circle $3/4"$ [19mm] below the top edge of the circle as shown in section A-A #2. Finish pouring concrete outside the circle to the top of the circle or to the required level for an artificial surface.

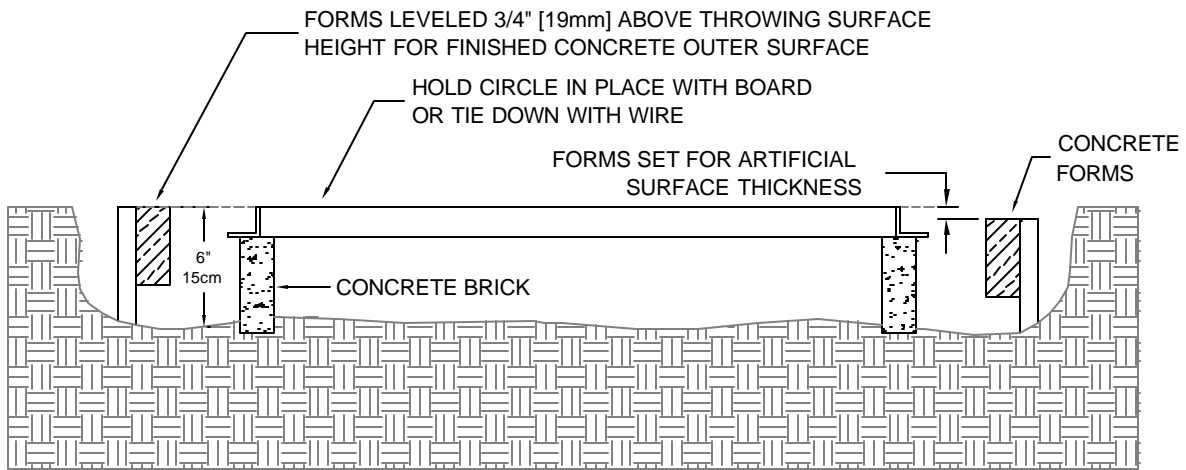

SECTION A-A #1

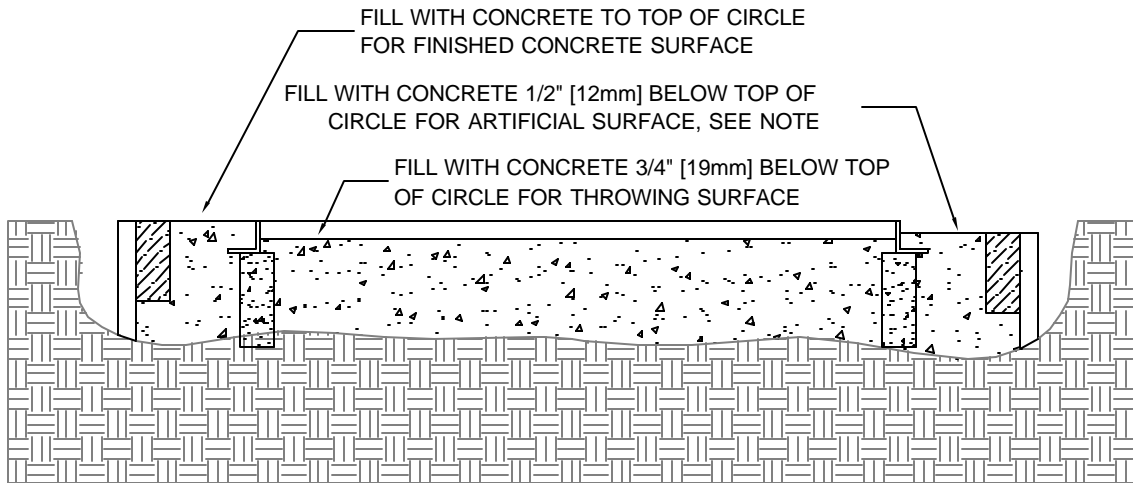

SECTION A-A #2

NOTE: FOR ARTIFICIAL TRACK SURFACES, THE DISTANCE THE CONCRETE IS FINISHED BELOW THE TOP OF THE CIRCLE SHOULD MATCH THE THICKNESS OF THE SURFACE TO BE INSTALLED.

Proprietary rights of ABT, Inc. are included in the information disclosed herein. The recipient, by accepting this document, agrees that neither this document nor the information disclosed herein nor any part thereof shall be copied, reproduced or transferred to others for manufacturing or for any other purpose except as specifically authorized in writing by ABT, Inc..

SportsEdge A Division of ABT, Inc. P.O. Box 837 * 259 Murdock Road Troutman, NC 28166 800-334-6057	TITLE: SE375 - Installation		
	DRAWN BY: C.C.C.	CHECKED BY:	DRAWING NUMBER: SE375-3
SCALE: NONE	DATE: 4/27/05	A—	
<small>DISCLAIMER : The customer and the customer's architects, engineers, consultants and other professionals are completely responsible for the selection, installation, and maintenance of any product purchased from ABT, and EXCEPT AS EXPRESSLY PROVIDED IN ABT'S STANDARD WARRANTIES, ABT MAKES NO WARRANTY, EXPRESS OR IMPLIED, AS TO THE SUITABILITY, DESIGN, MERCHANTABILITY, OR FITNESS OF THE PRODUCT FOR CUSTOMER'S APPLICATION. Copies of ABT's standard warranties are available upon request.</small>			

SE375 - ALUMINUM DISCUS CIRCLE DEPRESSED PAD INSTALLATION

ALTERNATE INSTRUCTIONS FOR SETTING CIRCLE AND POURING PAD

1. Position the circle in the center of the forms as shown in section A-A #1. The top edge of the circle must be held even with the top of the forms. If artificial track surface is to be installed around the circle, the top edge of the circle must be even with this surface. The circle forms should be lowered to match the thickness of the surface to be installed.
2. If required, install a drain. Position the drain to the side of the circle according to local requirements. Drains must not interfere with the athlete's throw.
3. Pour concrete outside of the circle and vibrate thoroughly to ensure there are voids under the plywood spacer. Finish pouring concrete outside the circle to the top of the circle or to the required level for an artificial surface.

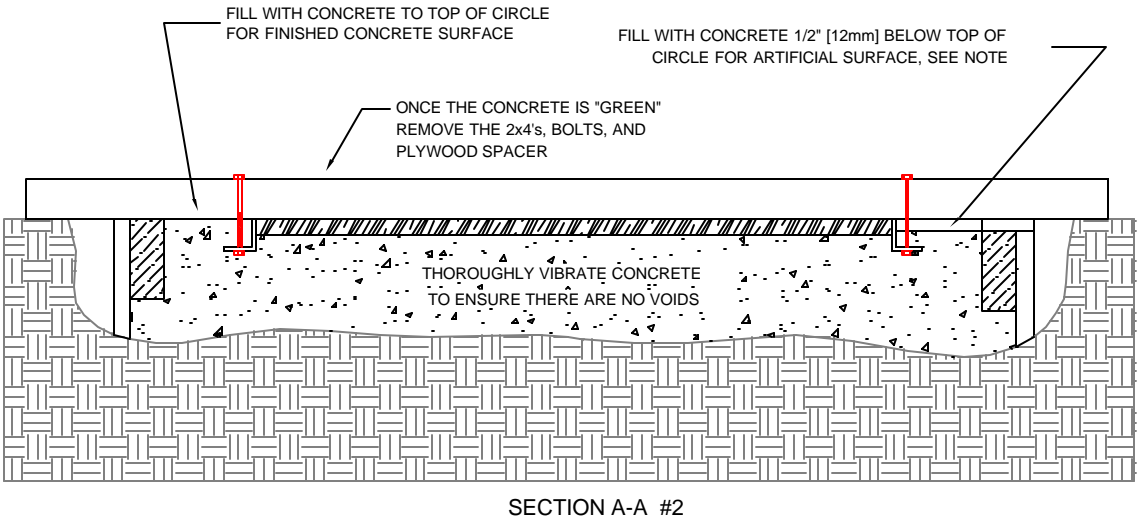
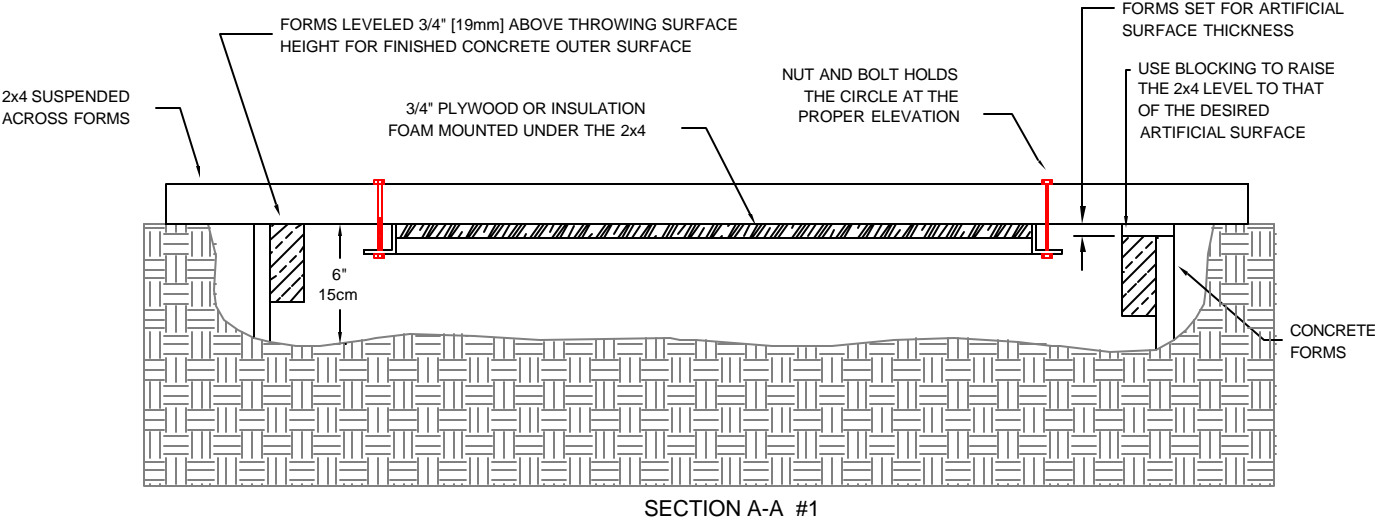

NOTE: FOR ARTIFICIAL TRACK SURFACES, THE DISTANCE THE CONCRETE IS FINISHED BELOW THE TOP OF THE CIRCLE SHOULD MATCH THE THICKNESS OF THE SURFACE TO BE INSTALLED.

Proprietary rights of ABT, Inc. are included in the information disclosed herein. The recipient, by accepting this document, agrees that neither this document nor the information disclosed herein nor any part thereof shall be copied, reproduced or transferred to others for manufacturing or for any other purpose except as specifically authorized in writing by ABT, Inc..

SportsEdge A Division of ABT, Inc. P.O. Box 837 * 259 Murdock Road Troutman, NC 28166 800-334-6057	TITLE: SE375 - Installation		
	DRAWN BY: C.C.C.	CHECKED BY:	DRAWING NUMBER: SE375-4
SCALE: NONE	DATE: 4/27/05	REVISION: A-	
<small>DISCLAIMER : The customer and the customer's architects, engineers, consultants and other professionals are completely responsible for the selection, installation, and maintenance of any product purchased from ABT, and EXCEPT AS EXPRESSLY PROVIDED IN ABT'S STANDARD WARRANTIES, ABT MAKES NO WARRANTY, EXPRESS OR IMPLIED, AS TO THE SUITABILITY, DESIGN, MERCHANTABILITY, OR FITNESS OF THE PRODUCT FOR CUSTOMER'S APPLICATION. Copies of ABT's standard warranties are available upon request.</small>			